



Certificado Nº SGI 3198065/11



Certificado Nº SGI 3198065/12

BEAM CLAMP BCA

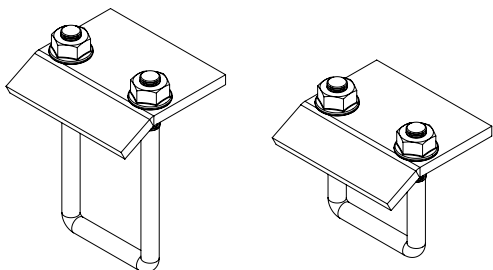

Available with M10 thread clamp in different lengths depending on the profil: 41x41, 82x41.

Coating: HDG.

Characteristics:

- Metallic
- Non-flame propagating componen
- Product with electrical continuity
- With metallic coating, resistance to correosion:

HDG: class 6

ASSEMBLY INSTRUCTIONS

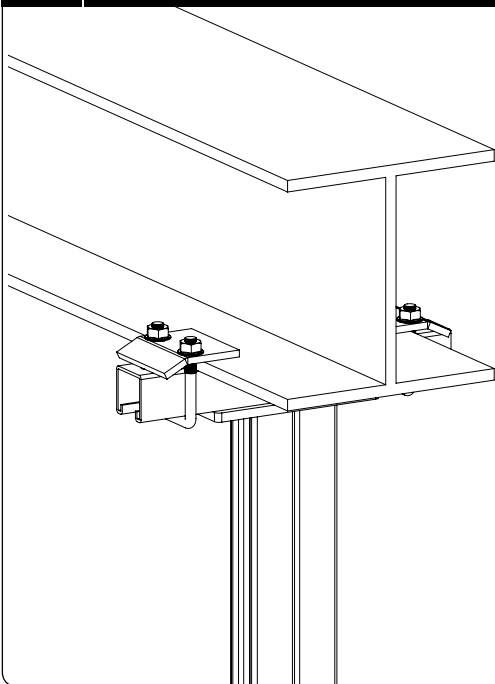

- 41/82 Beam clamp is used to fix BASORPROFILE 41/82 profiles to beam structures usually in the position shown in the picture..
- The product includes: Beam clamp and M10 hardware.
- Is it possible to fix 41x41 profil in both positions.
 - To fix accessories to open side of 41 profile use Spring Nut with DIN 933 Bolt.
 - To fix accessories to perforated bottom side of 41x41 profile use Din 912 bolts with DIN 934 nuts.
- Maximum torque 17,5 Nm

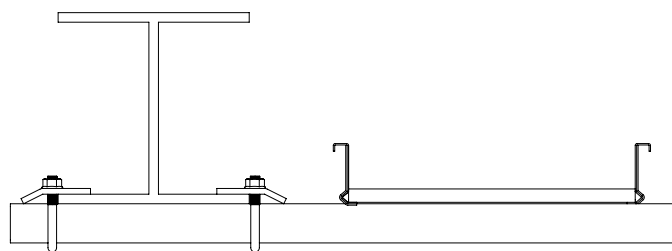

Related products:

Profiles and accessories of BASORPROFILE 41/82 family.